

Antenna

GPS antenna



General features:

- ▶ 12-channel receiver L1 = 1 575 MHz.
- ▶ Data standard : NMEA 0183
- ▶ Data transmission: RS485, 4800 bauds, 8 data bits, 1 stop bit, no parity.
- ▶ The antenna delivers every second the time message ZDA then GGA.
- ▶ Power supply: 5 to 15 V DC (from the SIGMA or the system to be synchronised).
- ▶ Horizontal and outdoor installation on the roof or on a mast.
- ▶ Possibility to install the antenna behind a window or under a plastic roof.
- ▶ Connection to the system to be synchronised with one single cable.
- ▶ Cable is 4 wires section 0.25 mm², 20 m provided with the antenna.
- ▶ Grey ABS casing with swivelling support to point the sky, fixing with 1 screw Ø 4 mm.
- ▶ Operating temperature: -30 to +70 °C.
- ▶ Storage temperature: -40 to +85 °C.
- ▶ IP67, IK04 protection.

Operation:

- ▶ A yellow LED indicates the operation of the antenna.
- ▶ The LED flashes every second when the antenna is synchronised.
- ▶ The LED remains on when the antenna is not synchronised.
- ▶ The LED is off, if the antenna is not supplied with power.
- ▶ The LED is visible from under.

Norms:

- ▶ EN 60950: safety of information technology equipment,
- ▶ EN 61000-6-1: immunity standard of information technology equipment,
- ▶ EN 61000-6-3: emission standard of information technology equipment.

DC Power	5V	15V
Maximal consumption	70mA	30mA
Maximal cable length	25m	300m

Dimensions in mm

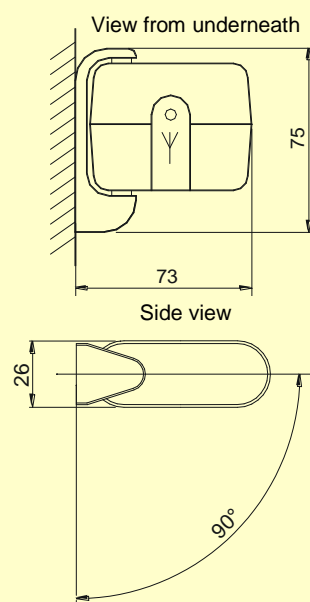

Reference:

- ▶ GPS antenna

907 037



Réf. 643061 H