

Digital clock

Digital clock

Opalys 7

Description:

- ▶ Indoor clock with backlit liquid crystal display (LCD).
- ▶ Hour display fixed or alternated with date or week number.
- ▶ Extra flat casing.
- ▶ External power supply 230V or PoE (Power over Ethernet) for NTP version.
- ▶ Casing colour: aluminium.
- ▶ Versions: independent quartz, radio synchronized (FI or DCF), DHF receiver, impulse slave movement, IRIG B/AFNOR coded time receiver or NTP receiver.



Technical features:

- ▶ 12 or 24 hour display mode.
- ▶ Automatic summer/winter time changeover and perpetual calendar with multi-time zones.
- ▶ Readability 25 metres, angle of vision 160°.
- ▶ Permanent data saving.
- ▶ Accuracy of the time quartz base: 0.2 second/day.
- ▶ Absolute time accuracy with optional radio synchronisation.
- ▶ ABS casing, IP40 IK02.
- ▶ PoE consumption: 4 W maximum; Class 0 device.
- ▶ Silent operation.
- ▶ Programming and time setting through 2 buttons.
- ▶ Operating temperature: from 0 to 50°C.
- ▶ Humidity: up to 80% at 40°C.
- ▶ Weight : 0.7 Kg.

Norms:

- ▶ NF EN50081-1: generic emission standard.
- ▶ NF EN50082-1: generic immunity standard.
- ▶ NF EN60950: safety of information technology equipment.

Dimensions in mm

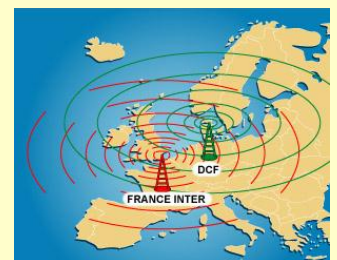
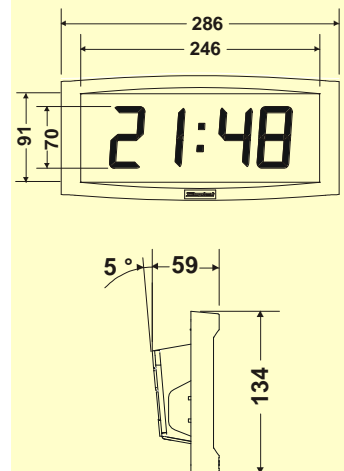

France Inter and DCF transmitter

Opalys 7 references

- | | |
|---|----------|
| ▶ Radio synchronised France Inter | 938 122A |
| ▶ Radio synchronised DCF | 938 124A |
| ▶ Slave movement on impulses or IRIG B/AFNOR receiver | 938 142A |
| ▶ DHF radio receiver | 938 133A |
| ▶ NTP PoE receiver | 938 162A |



Digital clock

Digital clock

Opalys 7



Opalys 7
on table support

Display modes:

- Hour only: ▶ 12h mode, ①
 ▶ 24h mode, ②
 or alternate with : ▶ Day-Month (31 :12), ③
 ▶ Month-Day (12 :31), ④
 ▶ Year, ⑤
 ▶ Week number, ⑥.

Movements and synchronisation:

Quartz movement

- ▶ The clock is totally independent, the time information comes from its own time basis.
- ▶ Automatic summer/winter time changeover.

DHF movement

- ▶ The clock is radio-synchronised by a DHF transmitter.
- ▶ Automatic summer/winter time changeover.

FI or DCF Radio synchronised movement

- ▶ The clock is independent, the time information comes from its own time basis which is rectified, in case of drift, by comparing it to the FI or DCF transmitter signal.
- ▶ The radio synchronisation permit to display the time with perfect accuracy.
- ▶ Automatic summer/winter time changeover.

IRIG B/AFNOR coded time receiver

- ▶ The coded time distribution consist in transmitting a complete time message each second : the setting on time of the receivers is realised automatically and speedily as soon as they are connected on the clock line.
- ▶ The IRIG B/AFNOR coded time does not transmit interference and is insensitive to other electrical interference.

24V minute impulses receiver movement

- ▶ The receiver clocks are connected to a distribution line and activated by means of electrical impulses transmitted every minute by the master clock.

NTP PoE receiver

- ▶ A NTP time server sends UTC time periodically on the Ethernet network. The clocks pick up the time messages, apply the relevant time zone and set themselves automatically to local time. PoE power is supplied to the clock through the network via the RJ45 plug.

①



②



③



④



⑤



⑥



Accessories:

- | | |
|---|---------|
| ▶ Wall support (supplied) | 202 266 |
| ▶ Table support | 938 902 |
| ▶ Double sided bracket for wall or ceiling mounting | 938 901 |
| ▶ Double sided bracket for wall or ceiling mounting (long length) | 938 905 |
| ▶ Single or double sided bracket specific length for wall or ceiling mounting (Please specify on the order the fixing mode (wall or ceiling) and the length between the top of the clock and the fixing point). | 938 908 |

